



# SUSSMAN

## ELECTRIC BOILERS

ES Series

Lbs/Hr Sat. Steam: 36 to 542

KW Rating: 12 to 180

ASME Rating 100 PSIG

Operating PSIG Range 0-80 PSIG Max

### ES Electric Steam Boilers

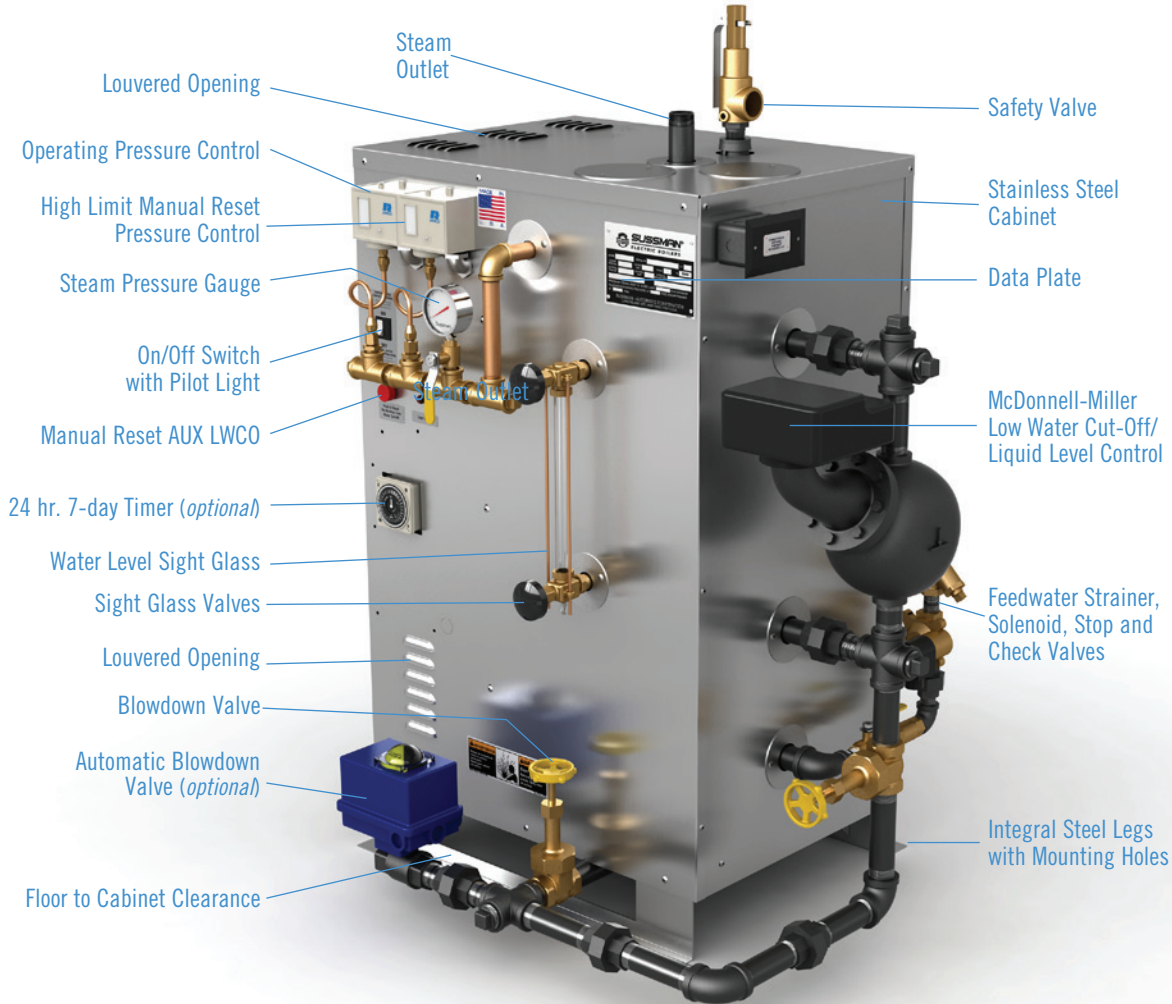

Typical boiler arrangement

Boiler Model No.	Water Inlet	Steam Outlet
ES 12 - ES 18	1/2" NPT	1/2" NPT
ES 24 - ES 72	1/2" NPT	1" NPT
ES 85 - ES 100	1/2" NPT	1-1/2" NPT
ES 135 - ES 180	1/2" NPT	2" NPT



Built to ASME Code **E**

Features Not Shown:

- Electronic Aux LWCO
- Section 1 Carbon Steel ASME Pressure Vessel
- Stainless Steel Heating Elements

### Sussman ES Packaged Electric Steam Boilers

Suitable for industries requiring efficient, high quality saturated steam, including laboratories, hospitals, industrial plants, pilot plants and chemical processing applications.

These versatile generators are perfect for almost any application requiring steam from 0-80 PSIG. Each unit is complete with automatic features, including pressure and liquid level controllers, ASME Code pressure vessel and safety valve and are fully tested under power. Each one must pass Sussman's rigid quality control inspection before it is shipped.

Sussman Electric Boilers - your source for fast economical steam energy.

### ES Series Features:

- Safe easy-to-use heat source. No on-site products of combustion
- Easy, quick to install, they require only a water feed connection and electrical hook-up
- Applications include: Steam for tanks, reactors, distillations, autoclaves, dyestuffs, cosmetics, paraffins, glues, steam jacketed kettles, sterilizers, pipe tracing and humidification.
- Built to Section 1 of ASME Boiler and Pressure Vessel Codes. UL listed.

## ES-Standard Features

- **WATER FEED SYSTEM** - Strainer, solenoid valve, stop valve and check valve factory wired and plumbed for direct connection to water line.
- **LOW WATER CUT-OFF/LEVEL CONTROL** - McDonnell Miller No.150 control automatically maintains proper water level, shutting off the boiler when water supply in the boiler drops below a safe operating level.
- **WATER LEVEL SIGHT GLASS** - Allows constant observation of water level while boiler is in operation.
- **MAIN ON/OFF SWITCH** - Allows manual operation of the boiler operating control circuit.
- **PILOT LIGHT** - Indicates control circuit's on/off condition.
- **INTEGRAL POWER CONTACTORS** - Magnetic contactors for energizing the boiler elements. Integrally mounted in the control unit.
- **BLOWDOWN/DRAIN VALVES** - Facilitates emptying the boiler pressure vessel and MM150 water column piping during blowdown sequence.
- **LONG LIFE HEATING ELEMENTS** - Industrial grade, heavy duty 0.420 inch diameter stainless steel heating elements, equipped with one piece resistance welded terminations for added strength and safety.
- **OPERATING PRESSURE CONTROL** - Resets automatically to maintain preset pressure within boiler.
- **ENERGY SAVINGS AND MINIMUM MAINTENANCE** - Pressure vessel insulation minimizes heat loss and maximizes energy savings, insured by fibrous glass material.
- **EASY CONTROL MAINTENANCE** - All control panels and components are easily accessible. Fully-louvered openings avoid component heat build-up.
- **NEMA 1 Louvered enclosure standard**
- **TRIM PRESSURE-** Factory standard 100 PSIG or 15 PSIG

## Meeting Code Requirements

- Pressure vessel rated at 100 PSIG to ASME Section 1. Vessel National Board Registered
- UL and cUL Listed
- Electrical construction conforms to NEC standards.

## Safety Features

- **STEAM SAFETY VALVE** - Automatically opens to reduce pressure should excessive steam cause pressure build-up.
- **STEAM PRESSURE GAUGE** - Allows visual observation of steam pressure over full range.
- **MANUAL RESET PRESSURE CONTROL** - Provides high limit pressure cut-out with manual reset.
- **AUXILIARY LWCO with Manual Reset** - Standard electronic back-up to primary MM150 control.

## Optional Equipment

- **OPTIONS AVAILABLE :** Motor/Pumps, Condensate Return Systems, Step Sequencers, Automatic Blowdown Systems, Blowdown Separators and Transformers.

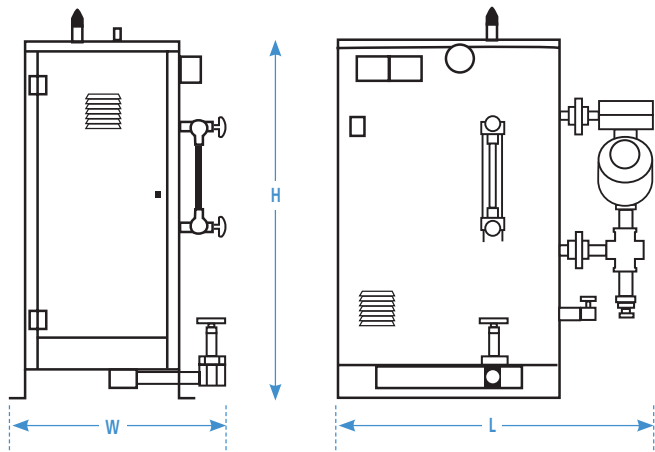

## Specifications for ES Boilers

Boiler Model	kW*	BHP Rating	Lbs./Hr. Steam**	3 Phase Voltaget	Amps	Dimensions (in)			Shipping Wt.
						W	L††	H	
ES-12*	12	1.22	36.2	208	34	20	28	36	200
				240	29				
				480	15				
ES-18*	18	1.84	54.2	208	50	20	28	36	200
				240	44				
				480	22				
ES-24*	24	2.45	72.3	208	67	23	33	44	330
				240	58				
				480	29				
ES-30*	30	3.06	90.4	208	84	23	33	44	330
				240	73				
				480	37				
ES-36*	36	3.67	108	208	100	23	33	44	330
				240	87				
				480	44				
ES-48	48	4.90	145	208	134	23	33	44	330
				240	116				
				480	59				
ES-60	60	6.12	181	208	167	23	33	44	330
				240	145				
				480	73				
ES-72	72	7.35	217	208	200	23	33	44	330
				240	174				
				480	87				
ES-85	85	8.5	256	208	236	28	34	59	680
				240	204				
				480	102				
ES-100	108	11.0	325	208	300	28	34	59	680
				240	260				
				480	130				
ES-135	144	14.6	433	208	400	30	36	59	680
				240	347				
				480	173				
ES-160	158	16.1	475	240	379	30	36	61	680
				480	190				
				240	434				
ES-180	180	18.4	542	480	217	30	36	61	680

Notes: \* Single phase available  
 \*\*Lbs/hr steam at 212° F with 50° F feedwater  
 † Other voltages available  
 ††Allow 21 inches for heating element removal

PUR 100217 8/13